

# Powercheck Valve

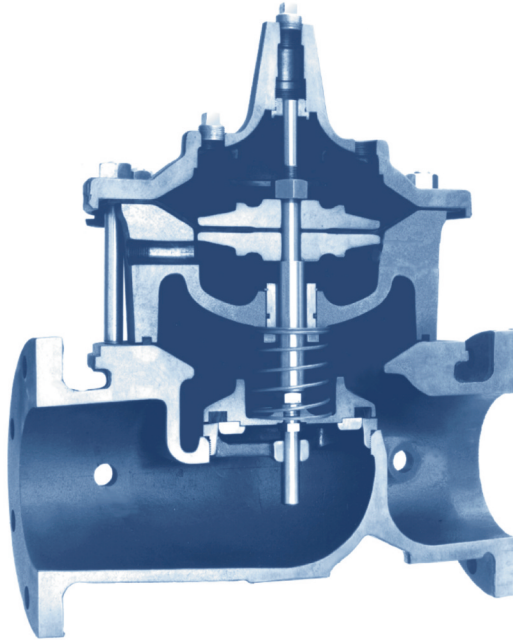

- Built-in Automatic Check Valve
- Globe or Angle Pattern
- Drip-Tight, Positive Seating
- Threaded or Flanged Ends
- Packless Construction

The Cla-Val Model 100-30 Powercheck Valve is a hydraulically operated diaphragm valve with a built-in check feature to prevent return flow. Available in globe or angle pattern, it consists of four major components: body, intermediate chamber, diaphragm assembly, and cover. The diaphragm assembly is the only moving part.

The diaphragm assembly is guided top, center and bottom by a precision machined stem and utilizes a non-wicking diaphragm of nylon fabric bonded with synthetic rubber. A synthetic rubber disc retained on three and one half sides forms a drip-tight seal with the renewable seat when pressure is applied above the diaphragm. When pressure above the diaphragm is relieved, the valve opens wide. The rate of closing or opening can be controlled by modulating flow into or out of the diaphragm chambers.

When a pressure reversal occurs, the valve will immediately close, preventing reverse flow thru the valve. The split stem will allow the disc retainer assembly to check closed regardless of the position of the diaphragm.

## Principle of Operation

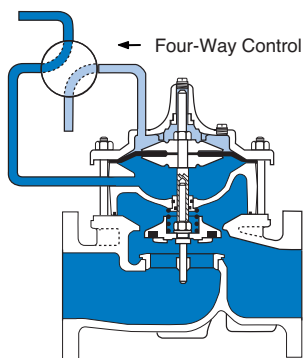

### Full Open Operation

When operating pressure below the diaphragm is greater than the pressure in the cover chamber, the valve is held open, allowing full flow.

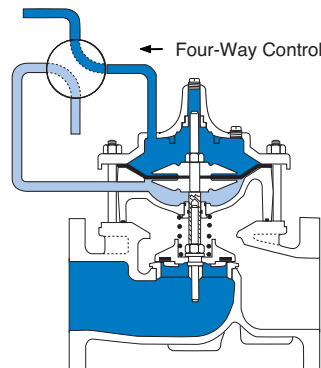

### Tight Closing Operation

When pressure below the diaphragm is relieved and operating pressure is applied to the cover chamber, the valve closes drip-tight.

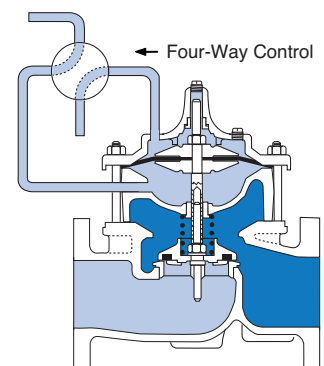

### Check Action

When a static condition or pressure reversal occurs, the split stem design allows the valve to instantly check closed. Return flow is prevented regardless of the diaphragm's position.

## Cla-Val 100-30 Powercheck Main Valve Specifications

### Available Sizes

Pattern	Threaded	Flanged
Globe (inches)	2½" - 3"	2½" - 8"
Globe (mm)	65 - 80 mm	65 - 200 mm
Angle (inches)	2½" - 3"	2½" - 8"
Angle (mm)	65 - 80 mm	65 - 200 mm

### Operating Temp. Range

Fluids
-40° to 180° F -40° to 82° C

### Pressure Ratings (Recommended Maximum Pressure - psi)

Valve Body & Cover		Pressure Class		
		Flanged		
Grade	Material	ANSI Standards*	150 Class	300 Class
ASTM A536	Ductile Iron	B16.42	250	400
ASTM A216-WCB	Cast Steel	B16.5	285	400
UNS 87850	Bronze	B16.24	225	400

Note: \* ANSI standards are for flange dimensions only.  
Flanged valves are available faced but not drilled.  
**Valves for higher pressure are available; consult factory for details**



2 1/2" Globe, Threaded

### Materials

Component	Standard Material Combinations		
Body & Cover	Ductile Iron	Cast Steel	Bronze
Available Sizes (inches)	2½" - 8"	2½" - 8"	2½" - 8"
Available Sizes (mm)	65 - 200 mm	65 - 200 mm	65 - 200 mm
Disc Retainer & Diaphragm Washer	Cast Iron	Cast Steel	Bronze
Trim: Disc Guide, Seat & Cover Bearing	Bronze is Standard Stainless Steel is optional		
Disc	Buna-N® Rubber		
Diaphragm	Nylon Reinforced Buna-N® Rubber		
Stem, Nut & Spring	Stainless Steel		

For material options not listed, consult factory.  
Cla-Val manufactures valves in more than 50 different alloys.

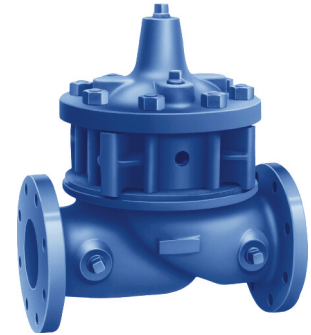

4" Angle, Globe

### Options

#### Epoxy Coating - suffix KC

An FDA approved fusion bonded epoxy coating for use with cast iron, ductile iron or steel valves. This coating is resistant to various water conditions, certain acids, chemicals, solvents and alkalis. Epoxy coatings are applied in accordance with AWWA coating specifications C116-03. Do not use with temperatures above 175°F/80° C.

#### Viton® Rubber Parts - suffix KB

Optional diaphragm, disc and o-ring fabricated with Viton® synthetic rubber. Viton® is well suited for use with mineral acids, salt solutions, chlorinated hydrocarbons, and petroleum oils; and is primarily used in high temperature applications up to 250° F/120°C. Do not use with epoxy coating above 175°F/80° C.

#### Heavy Spring - suffix KH

The heavy spring option is used in applications where there is low differential pressure across the valve, and the additional spring force is needed to help the valve close. The option is best suited for valves used in on-off (non-modulating) service.

**For assistance in selecting appropriate valve options or valves manufactured with special design requirements, please contact our Regional Sales Office or Factory.**

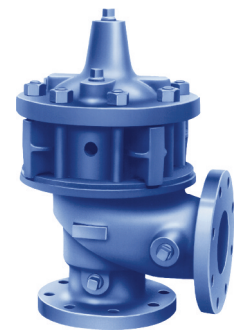

4" Angle, Flanged

## Cla-Val 100-30 Powercheck Main Valve Functional Data

Valve Size		Inches	2½	3	4	6	8
		mm.	65	80	100	150	200
C <sub>V</sub> Factor	Globe Pattern	Gal./Min. (gpm.)	85	115	200	440	770
		Litres/Sec. (l/s.)	20	28	48	106	185
	Angle Pattern	Gal./Min. (gpm.)	101	139	240	541	990
		Litres/Sec. (l/s.)	24	33	58	130	238
Equivalent Length of Pipe	Globe Pattern	Feet (ft.)	53	85	116	211	291
		Meters (m.)	16	26	35	64	89
	Angle Pattern	Feet (ft.)	37	58	80	139	176
		Meters (m.)	12	18	25	43	54
K Factor	Globe Pattern		4.6	6.0	5.9	6.2	6.1
	Angle Pattern		3.3	4.1	4.1	4.1	3.7
Liquid Displaced from Cover Chamber When Valve Opens		Fl. Oz	—	—	—	—	—
		U.S. Gal.	.04	.08	.17	.53	1.26
		ml	163	303	643	—	—
		Litres	—	—	—	2.0	4.8

\*Estimated

### C<sub>V</sub> Factor

Formulas for computing C<sub>V</sub> Factor, Flow (Q) and Pressure Drop (ΔP):

$$C_V = \frac{Q}{\sqrt{\Delta P}} \quad Q = C_V \sqrt{\Delta P} \quad \Delta P = \left( \frac{Q}{C_V} \right)^2$$

### K Factor (Resistance Coefficient)

The Value of K is calculated from the formula:  $K = \frac{894d^4}{C_V^2}$   
(U.S. system units)

### Equivalent Length of Pipe

Equivalent lengths of pipe (L) are determined from the formula:  $L = \frac{Kd}{12f}$   
(U.S. system units)

### Fluid Velocity

Fluid velocity can be calculated from the following formula:  $V = \frac{.4085 Q}{d^2}$   
(U.S. system units)

### Where:

C<sub>V</sub> = U.S. (gpm) @ 1 psi differential at 60° F water  
or

= (l/s) @ 1 bar (14.5 PSIG) differential  
at 15° C water

d = inside pipe diameter of Schedule 40 Steel Pipe (inches)

f = friction factor for clean, new Schedule 40 pipe  
(dimensionless) (from Cameron Hydraulic Data,  
18th Edition, P 3-119)

K = Resistance Coefficient (calculated)

L = Equivalent Length of Pipe (feet)

Q = Flow Rate in U.S. (gpm) or (l/s)

V = Fluid Velocity (feet per second) or (meters per second)

ΔP = Pressure Drop in (psi) or (bar)

## Model 100-30 Flow Chart (Based on normal flow through a wide open valve)

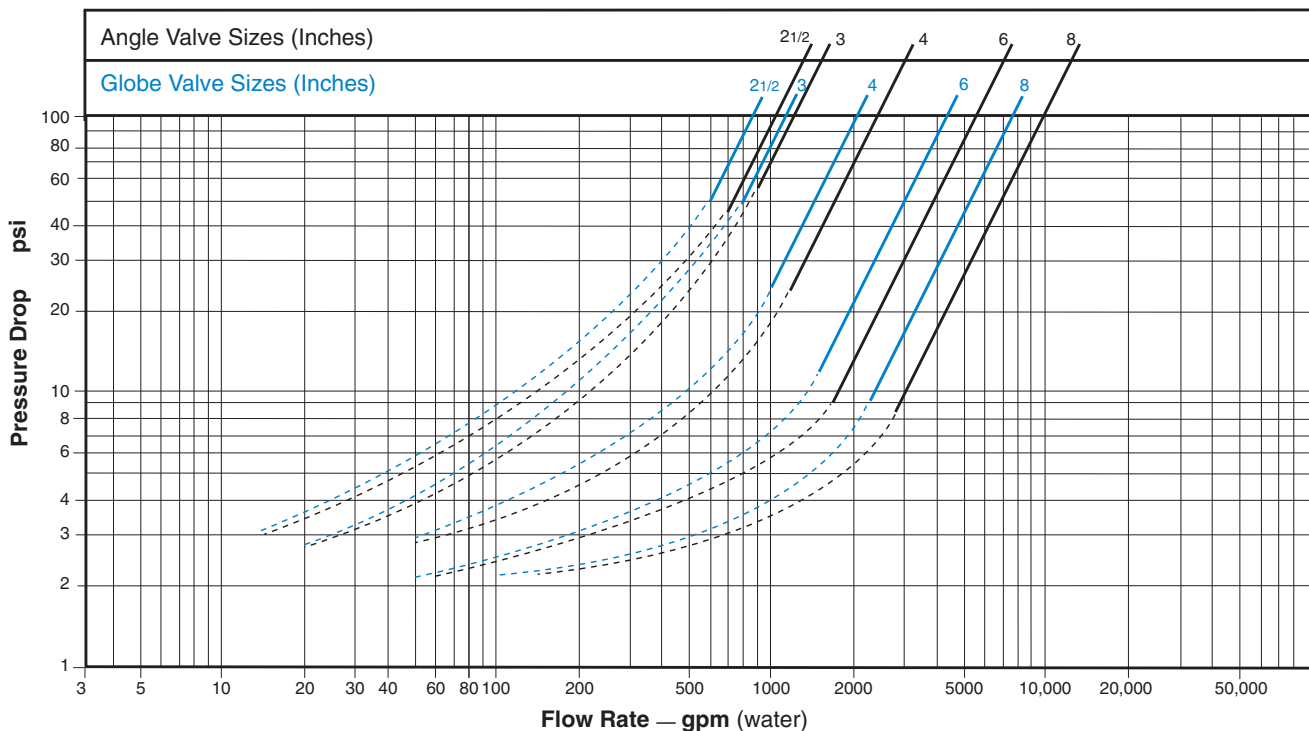

## Cla-Val 100-30 Powercheck Main Valve Dimensions

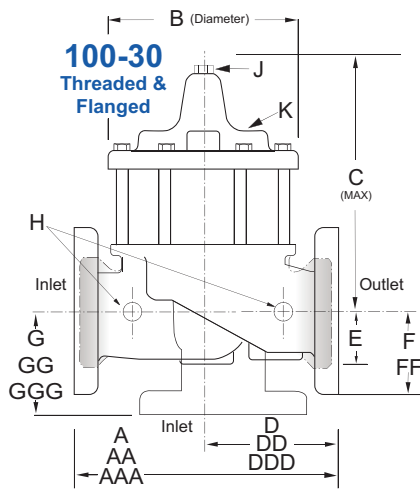

Valve Size (Inches)	2 1/2	3	4	6	8
A Threaded	11.00	12.50	—	—	—
AA 150 ANSI	11.00	12.00	15.00	20.00	25.38
AAA 300 ANSI	11.62	13.25	15.62	21.00	26.38
B Diameter	8.00	9.12	11.50	15.75	20.00
C Maximum	10.31	11.19	14.25	18.44	21.81
D Threaded	5.50	6.25	—	—	—
DD 150 ANSI	5.50	6.00	7.50	10.00	12.69
DDD 300 ANSI	5.81	6.63	7.81	10.50	13.19
E	1.69	2.06	3.19	4.31	5.31
F 150 ANSI	3.50	3.75	4.50	5.50	6.75
FF 300 ANSI	3.75	4.13	5.00	6.25	7.50
G Threaded	4.00	4.50	—	—	—
GG 150 ANSI	4.00	4.00	5.00	6.00	8.00
GGG 300 ANSI	4.31	4.38	5.31	6.50	8.50
H NPT Body Tapping	0.50	0.50	0.75	0.75	1.00
J NPT Cover Center Plug	0.50	0.50	0.75	0.75	1.00
K NPT Cover Tapping	0.50	0.50	0.75	0.75	1.00
Stem Travel	0.70	0.80	1.10	1.70	2.30

Valve Size (Inches)	2 1/2	3	4	6	8
A Threaded	11.00	12.50	—	—	—
AA 150 ANSI	11.00	12.00	15.00	20.00	25.38
AAA 300 ANSI	11.62	13.25	15.62	21.00	26.38
B Diameter	8.00	9.12	11.50	15.75	20.00
C Maximum	10.31	11.19	14.25	18.44	21.81
D Threaded	5.50	6.25	—	—	—
DD 150 ANSI	5.50	6.00	7.50	10.00	12.69
DDD 300 ANSI	5.81	6.63	7.81	10.50	13.19
E	1.69	2.06	3.19	4.31	5.31
F 150 ANSI	3.50	3.75	4.50	5.50	6.75
FF 300 ANSI	3.75	4.13	5.00	6.25	7.50
G Threaded	4.00	4.50	—	—	—
GG 150 ANSI	4.00	4.00	5.00	6.00	8.00
GGG 300 ANSI	4.31	4.38	5.31	6.50	8.50
H NPT Body Tapping	0.50	0.50	0.75	0.75	1.00
J NPT Cover Center Plug	0.50	0.50	0.75	0.75	1.00
K NPT Cover Tapping	0.50	0.50	0.75	0.75	1.00
Stem Travel	0.70	0.80	1.10	1.70	2.30

Cla-Val Control Valves operate with maximum efficiency when mounted in horizontal piping with the main valve cover UP, however, other positions are acceptable. Due to component size and weight of 8 inch and larger valves, installation with cover UP is advisable. We recommend isolation valves be installed on inlet and outlet for maintenance. Adequate space above and around the valve for service personnel should be considered essential. A regular maintenance program should be established based on the specific application data. However, we recommend a thorough inspection be done at least once a year. Consult factory for specific recommendations.